

THERMOSTATIC MIXING VALVE

ECO-MIX™

MODEL 170-LF

LEAD FREE THERMOSTATIC POINT OF USE MIXING VALVE

MODEL 3/8" inlets, 3/8" outlet, compression connections

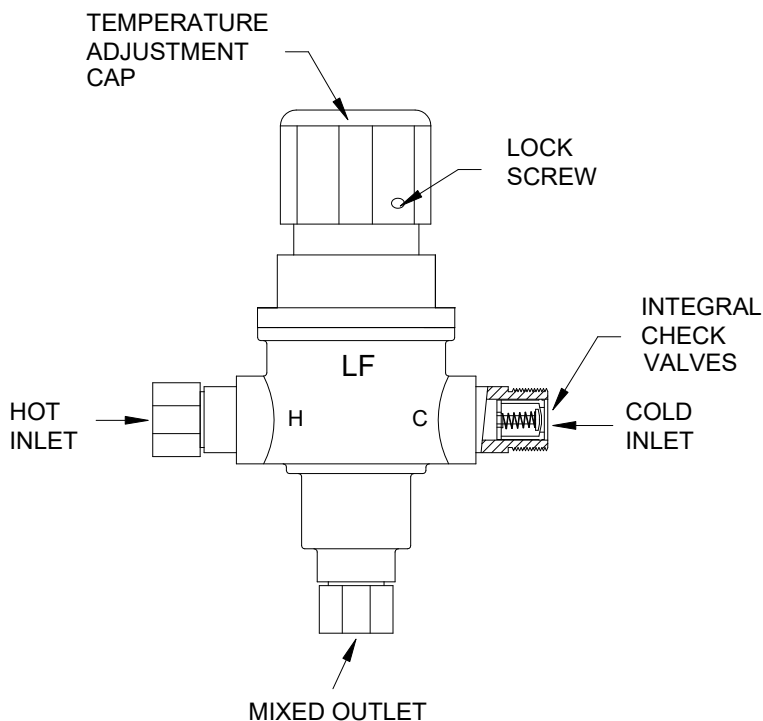

MATERIALS:

- Lead Free Bronze body
- Locked temperature adjustment cap (vandal resistant)
- Copper encapsulated thermostat assembly with polymer thermoplastic shuttle
- Stainless steel springs
- Integral check valves on hot and cold inlets
- Inlet screens on hot and cold inlets
- Compression fittings on inlets and outlet

PRESSURE-TEMPERATURE:

- Minimum Flow: 0.25 GPM (.95 l/Min)
- Maximum Pressure: 125 PSI (8.6 BAR)
- Maximum Hot Water temperature: 180°F (82°C)
- Approach Temperature 5°F (2.8°C) above set point.
- Temperature adjustment range, 90-140°F (32-60°C) **

OPTIONS:

- ___ BP- Cold water By-Pass (shipped loose)
- ___ CP- Chrome Plated
- ___ BRKT- Mounting Bracket (shipped loose)

Certifications:

ASSE 1070



CSA



Certified to NSF61 thru the ASSE 1070 testing process

MINIMUM FLOW	PRESSURE DROP						PSI
	5	10	20	30	40	50	
	.35	.70	1.4	2.1	2.8	3.4	BAR
0.25	1.7	2.3	3.0	3.6	4.4	5.0	GPM
0.95	6.4	8.7	11.4	14	17	19	l/min

* 0.25 GPM minimum flow certified to ASSE 1070

****NOTE:** For temperatures outside of this valve's stated range, please see our line of bi-metal valves.

This product is certified to meet Low Lead requirements of wetted surface area containing less than 0.25% lead by weight

CABINET OPTIONS (see page 3):

- ___ SUFFIX STSTL REC- Recessed stainless steel cabinet
- ___ SUFFIX STSTL EXP- Exposed stainless steel cabinet
- ___ SUFFIX BWE REC- Recessed baked white cabinet
- ___ SUFFIX BWE EXP- Exposed baked white cabinet
- ___ SUFFIX RHH- Right hand hinge



1360 Elmwood Avenue, Cranston, RI 02910 USA
Phone: 401.461.1200 Fax: 401.941.5310
Email: info@leonardvalve.com
Web Site: <http://www.leonardvalve.com>

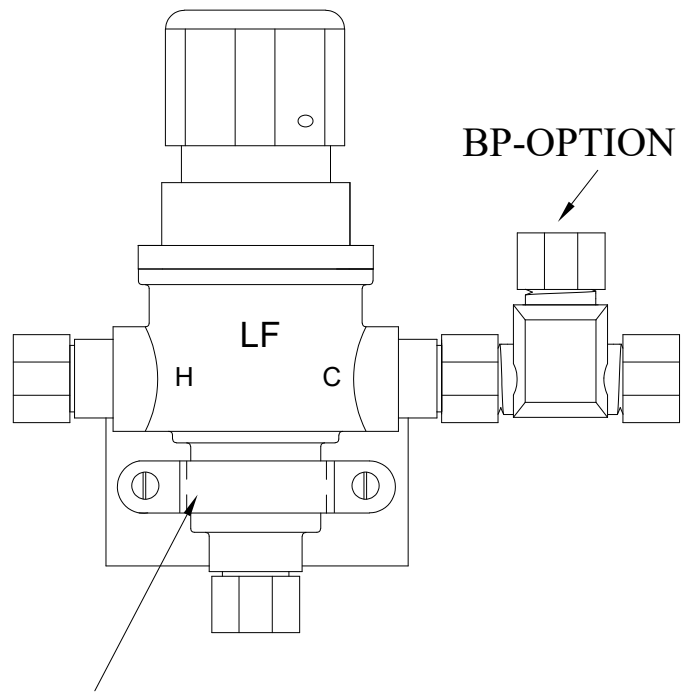
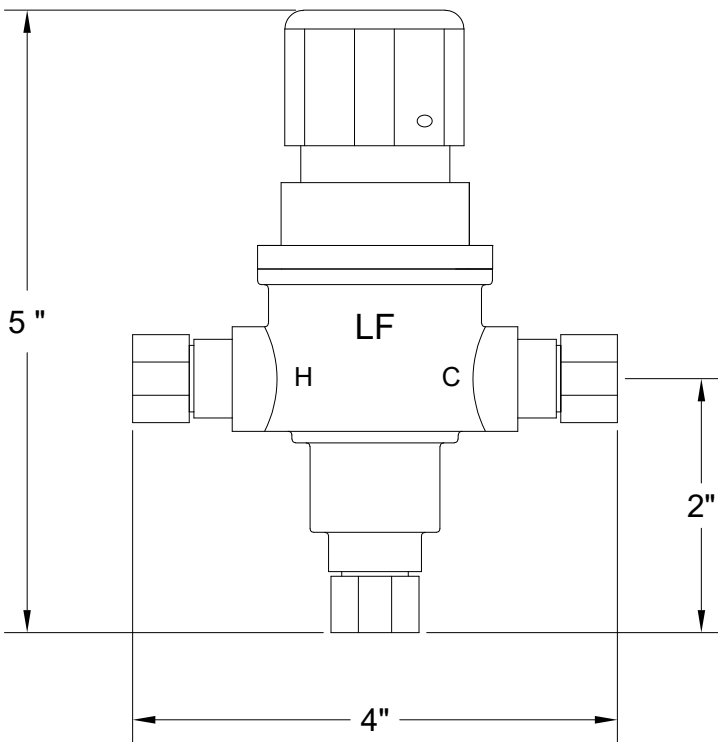

BRKT-OPTION

APPLICATION

The Model 170-LF is a high performance Temperature Actuated Mixing Valve used to supply single outlets. Can be used to supply one sensor faucet or one two handle manual faucet.

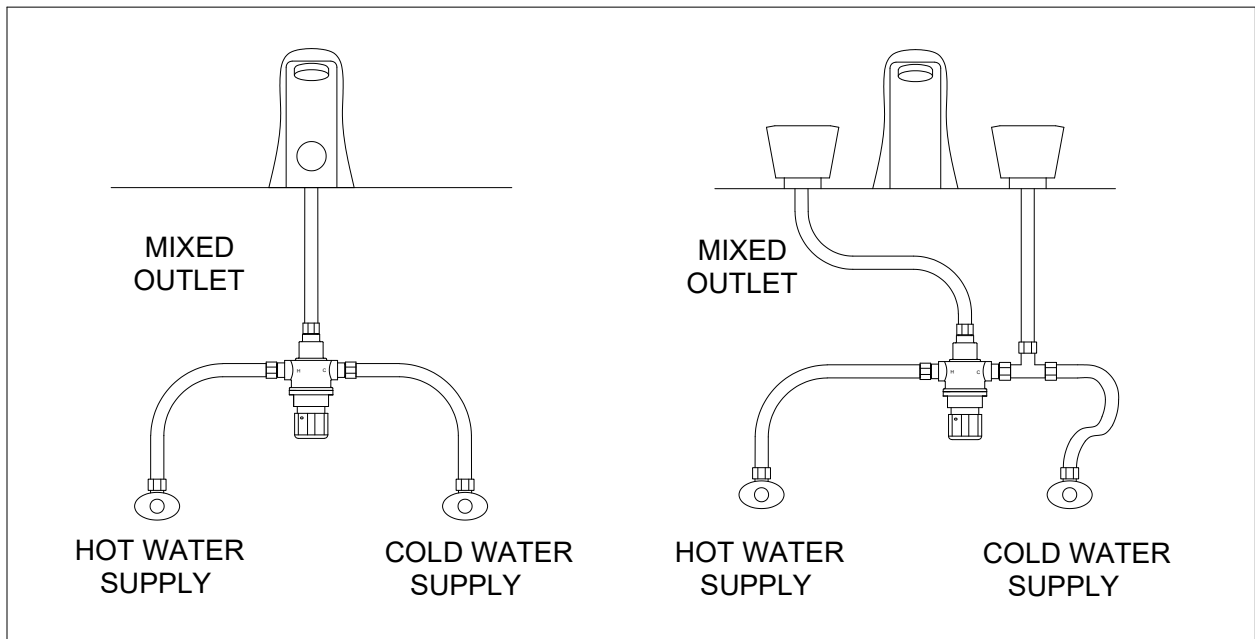

170-LF

170-LF-BP

Note: Leonard Valve Company reserves the right of product, or design modifications without notice or obligation.



1360 Elmwood Avenue, Cranston, RI 02910 USA

Phone: 401.461.1200 Fax: 401.941.5310

Email: info@leonardvalve.com

Web Site: <http://www.leonardvalve.com>

MODEL 170-LF CABINET OPTIONS

STSTL
REC

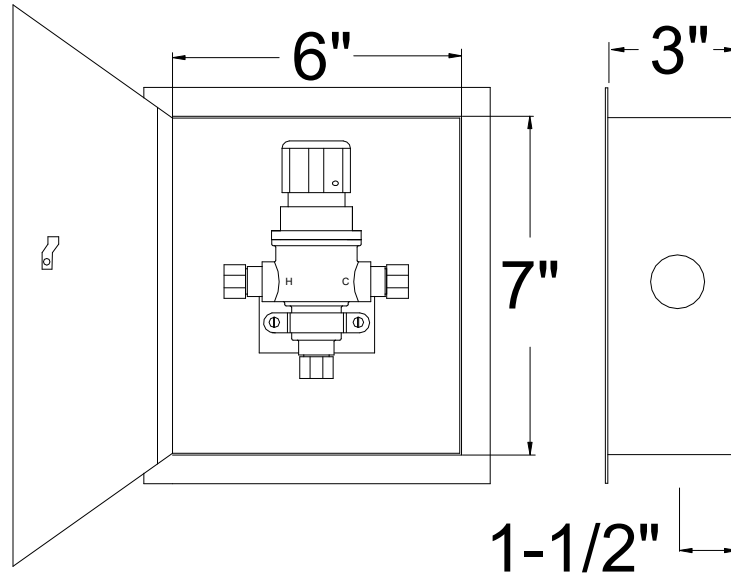

STSTL
EXP

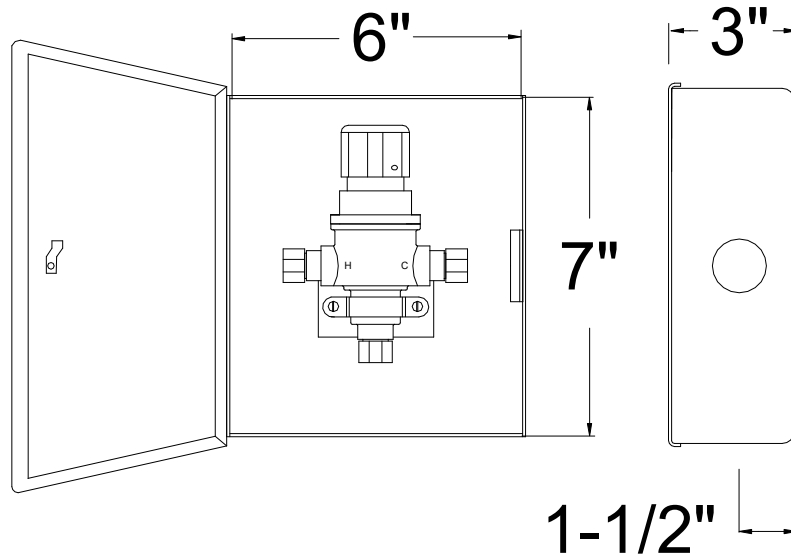

WARNING: This product can expose you to chemicals including lead, which is known to the State of California to cause cancer. For more information, go to www.P65Warnings.Ca.gov

Engineer's Approval	Job # _____
	Arch/Eng. _____
	Contractor _____



1360 Elmwood Avenue, Cranston, RI 02910 USA
 Phone: 401.461.1200 Fax: 401.941.5310
 Email: info@leonardvalve.com
 Web Site: <http://www.leonardvalve.com>