

EMERGENCY MIXING VALVES

ECO-MIX™

Cabinet Assembly for Drench or Combination Emergency Shower

3 - 126 GPM (11 - 477 l/min) flow rate
up to 45 PSI system pressure drop

TM-5125-LF-STSTL-EXP

DUAL MANIFOLD EMERGENCY MIXING VALVE SYSTEM WITH TEMPERATURE OVERRIDE PROTECTION

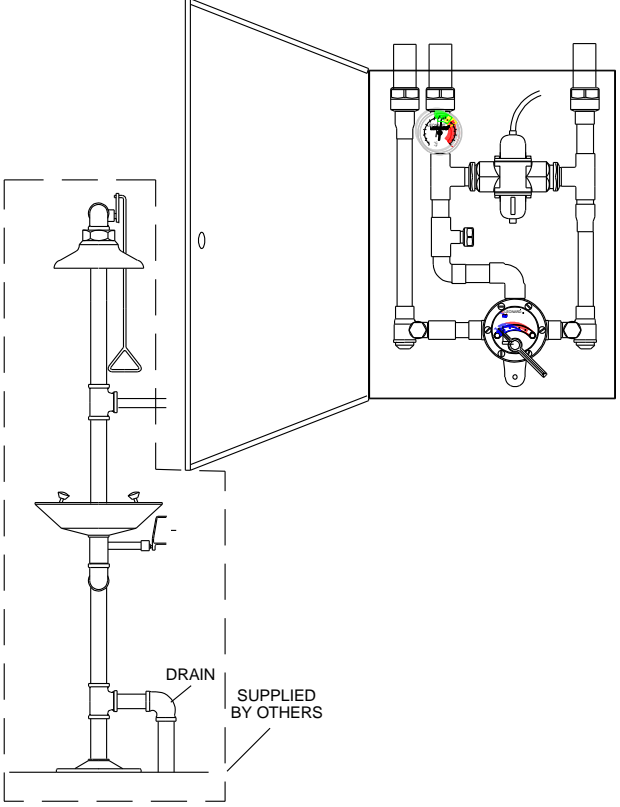

TM-5125-LF-STSTL-_____
PRIMARY EMERGENCY WATER MIXING VALVE

- DURA-trol® solid bimetal thermostat directly linked to valve porting to control the intake of hot and cold water and compensate for supply temperature and pressure fluctuations. DURA-trol® is highly responsive and cannot be damaged by extremes in temperature.
- Primary Mixing Valve can be set to the correct temperature for the application.
- Locking temperature regulator to prevent accidental movement set for 85°F (29°C).
- Primary valve will close down on failure of cold water supply.
- Primary valve with special built in cold water bypass capable of 40 GPM (151 l/min) @ 30 PSI (2.1 Bar) upon failure of hot water supply.
- Adjustable high temperature limit stop set for 90°F (32°C).
- Full 1¼" top inlets and 1½" top outlet.
- Integral wall support.
- Dial thermometer (0 to 140°F, -10 to 60°C).
- Rough bronze finish.
- Exposed stainless steel cabinet with hinged door and cylinder lock.
- Angle checkstops on inlets.
- Compliance.....ANSI Z 358.1

REDUNDANT THERMOSTATIC MIXING VALVE

- Stainless steel bellows thermostat is factory locked @ 90°F, 32°C (adjustable from 40°F to 100°F, 4°C to 32°C) to allow cold water to enter the outlet side of the Primary mixing valve.
- Remains fully closed until outlet temperature reaches 90°F (32°C).
- Will keep maximum temperature at 90°F should primary valve allow water in excess of 90°F (32°C).
- Rough bronze finish.
- Maximum supply temperature 180°F (82°C).
- Maximum supply pressure 125 PSI (8.6 Bar).

NOTE: Performance specifications above applicable when valve is tested to conditions specified per ASSE 1071

CABINET OPTIONS

- ___ SUFFIX BWE REC- Steel cabinet, baked white enamel recessed
- ___ SUFFIX STSTL REC- Stainless Steel recessed cabinet
- ___ SUFFIX BWE EXP- Exposed cabinet, baked white enamel
- ___ SUFFIX STSTL EXP- Exposed cabinet, Stainless steel
- ___ SUFFIX SEMI- Semi-recessed frame 4" deep
- ___ SUFFIX VIEW- View port on door
- ___ SUFFIX IT- Inlet thermometers



WARNING: This product can expose you to chemicals including lead, which is known to the State of California to cause cancer. For more information, go to www.P65Warnings.Ca.gov



1360 Elmwood Avenue, Cranston, RI 02910 USA
Phone: 401.461.1200 Fax: 401.941.5310
Email: info@leonardvalve.com
Web Site: <http://www.leonardvalve.com>

This product meets Low Lead requirements of wetted surface area containing less than 0.25% lead by weight

Engineer's Approval	Job # _____
	Arch/Eng. _____
	Contractor _____

CAUTION! All thermostatic water mixing valves have limitations. They will NOT provide the desired accuracy outside of their flow capacity range. Consult the Flow Capacity Chart and DO NOT OVERSIZE. Minimum flow must be no less than as indicated.

***NOTE:** A limit stop, set for 90°F (32°C), is simply a mechanical setting to prevent excessive handle rotation. If incoming water is hotter than 135°F (57°C), the temperature of the factory test, the valve when turned to full HOT may deliver water in excess of 90°F and the limit stop MUST BE RESET BY THE INSTALLER

EMERGENCY WATER MIXING VALVE FOR DRENCH OR COMBINATION EMERGENCY SHOWER

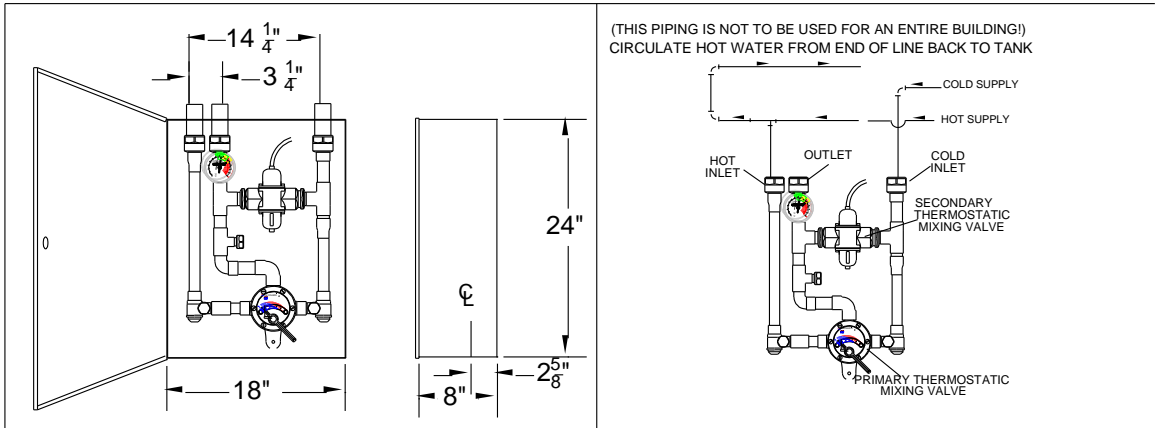

CAUTION! It may be necessary to recirculate the tempered water to the emergency shower should the piping be exposed to excessive hot or cold conditions. Consult factory for proper piping.

FLOW CAPACITIES

MODEL	IN	OUT	MINIMUM FLOW (GPM) L/MIN	INTERNAL COLD WATER BY-PASS	SYSTEM PRESSURE DROP									
					5	10	15	20	25	30	35	40	45	PSI
					.3	.7	1.0	1.4	1.7	2.1	2.4	2.8	3.1	BAR
TM-5125-LF	1 1/4"	1 1/2"	3	40	53	64	72	81	90	99	108	117	126	GPM
			11	151	201	242	273	307	341	374	409	443	477	L/MIN
MAXIMUM FLOW CAPACITY														

The Emergency eye/face wash Mixing Valve shall control and maintain the temperature of the water to the station. Unit shall be self contained and include a thermostatic water mixing valve, a dial thermometer on the outlet, angle checkstops, wall mounting bracket, piping and fittings factory assembled and tested, top or bottom inlets and top outlet, unit set for 85°F (29°C) and a maximum temperature of 90°F (32°C). The redundant valve remains fully closed until outlet temperature reaches 90°F (32°C), and will keep the maximum temperature at 90°F should the primary valve allow water in excess of this temperature. Unit must be able to be set to the correct temperature for the specific contaminant but must be locked in place to prevent changing of the temperature by accident. Unit must be checked weekly for performance in conjunction with the requirements of ANSI Z-358.1 2004. Unit shall be able to flow 40 GPM (151 l/min) at 30 PSI (2.1 Bar).

WARNING! IT IS THE RESPONSIBILITY OF THE SPECIFIER TO DETERMINE THE DELIVERED WATER TEMPERATURE TO EACH SAFETY FIXTURE. A COMFORTABLE RANGE IS 60°F TO 90°F (15° TO 35°C). IN CIRCUMSTANCES WHERE A CHEMICAL REACTION IS ACCELERATED BY WATER TEMPERATURE, A MEDICAL ADVISOR SHOULD BE CONSULTED FOR THE OPTIMUM TEMPERATURE FOR EACH APPLICATION.

Specifications are subject to change without notice!

CAUTION! All thermostatic water mixing valves have limitations. They will NOT provide the desired accuracy outside of their flow capacity range. Consult the Flow Capacity Chart and DO NOT OVERSIZE. Minimum flow must be no less than indicated.



1360 Elmwood Avenue, Cranston, RI 02910 USA

Phone: 401.461.1200 Fax: 401.941.5310

Email: info@leonardvalve.com

Web Site: <http://www.leonardvalve.com>