

ECO-MIX™

XL-200-SW-2PS-LF PARALLEL INSTALLATION WITH STRUT

HIGH LOW THERMOSTATIC MIXING VALVES

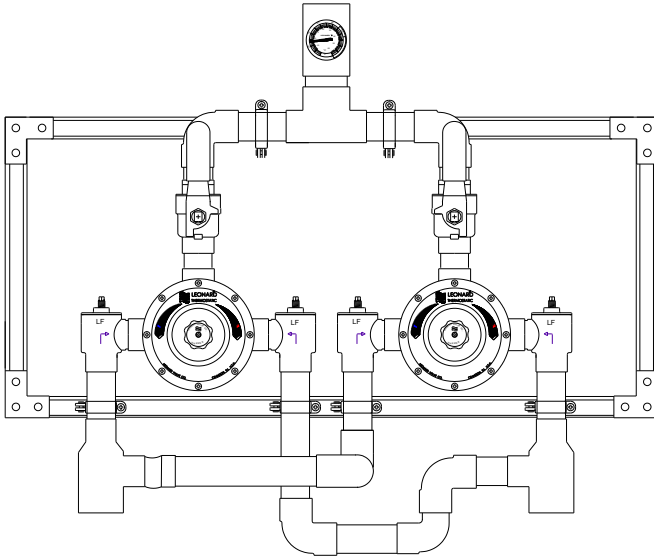

See page #2 for piping diagram

- High Low Thermostatic Water Mixing Valve with 10 GPM (38 l/min) minimum flow capacity +
- 3" inlets, 3" outlet (76mm X 76mm)
- Integral combination checkstops with strainers and wall support
- 125 PSI (8.6 BAR) maximum operating pressure
- Copper encapsulated thermostatic assembly with shuttle
- Locking temperature regulating handle set for 120°F(49°C)*
- Temperature adjustment range, 95-135°F (35-57°C) **
- Dial thermometer on outlet
- Factory assembled and tested
- Inlet manifold piping
- Internal parts of bronze, brass, and stainless steel
- Rough Bronze Finish

Valves are ASSE 1017 Certified



Valves are cUPC Certified



OPTIONS

- ___ SUFFIX **TC** Test connection (ship loose)
- ___ SUFFIX **IT** Inlet thermometers (ship loose)
- ___ **IBV200-2PS** -Inlet ball valves on all hot & cold inlets

NOTE: Leonard Valve Company reserves the right of product or design modification without notice or obligation



WARNING: This product can expose you to chemicals including lead, which is known to the State of California to cause cancer. For more information, go to www.P65Warnings.Ca.gov

****NOTE:** For temperatures outside of this valve's stated range, please see our line of bi-metal valves.

***NOTE:** A limit stop, set for 120°F (49°C), is simply a mechanical setting to prevent excessive handle rotation. If incoming water is hotter than 150°F (65.5°C), the temperature of the factory test, the valve when turned to full HOT may deliver water in excess of 120°F and the limit stop **MUST BE RESET BY THE INSTALLER**

Product is non-cancellable and non-returnable from date from order with factory. Signed submittal required with purchase order.

Valves are certified to meet Low-Lead requirements of wetted surface area containing less than 0.25% lead by weight. All other fittings and components, the sum total of which comprise the wetted surface of this product contains less than one quarter of one percent of lead by weight.

DOUBLE FLOWRATE WHEN BOTH VALVES ARE OPERATING

SINGLE VALVE ASSEMBLY FLOWRATES SHOWN
(MINIMUM FLOW RATE HAS BEEN DOUBLED TO 10 GPM)

PRESSURE DROP											
MIN ⁺ FLOW	5	10	15	20	25	30	35	40	45	50	PSI
	0.3	0.7	1	1.4	1.7	2.1	2.4	2.8	3.1	3.4	BAR
10	69	96	117	135	148	163	174	188	198	208	GPM
38	216	363	443	511	560	617	659	712	750	787	l/min

+NOTE: The valve will maintain temperature with 0.5GPM flow from the domestic hot water loop when properly installed near the hot water source with a continuously operating recirculation pump.

Engineer's Approval

Job # _____

Arch/Eng. _____

Contractor _____

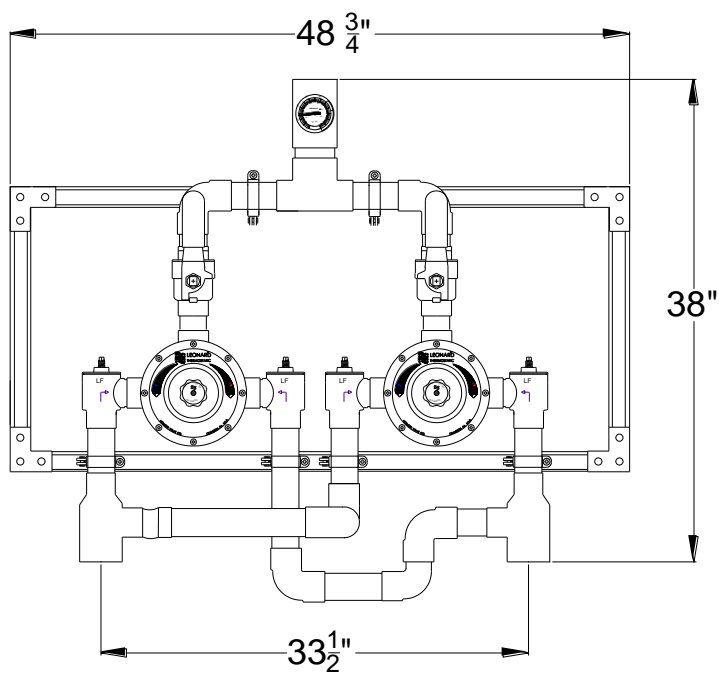

HIGH TEMPERATURE FIXTURES (IF APPLICABLE)

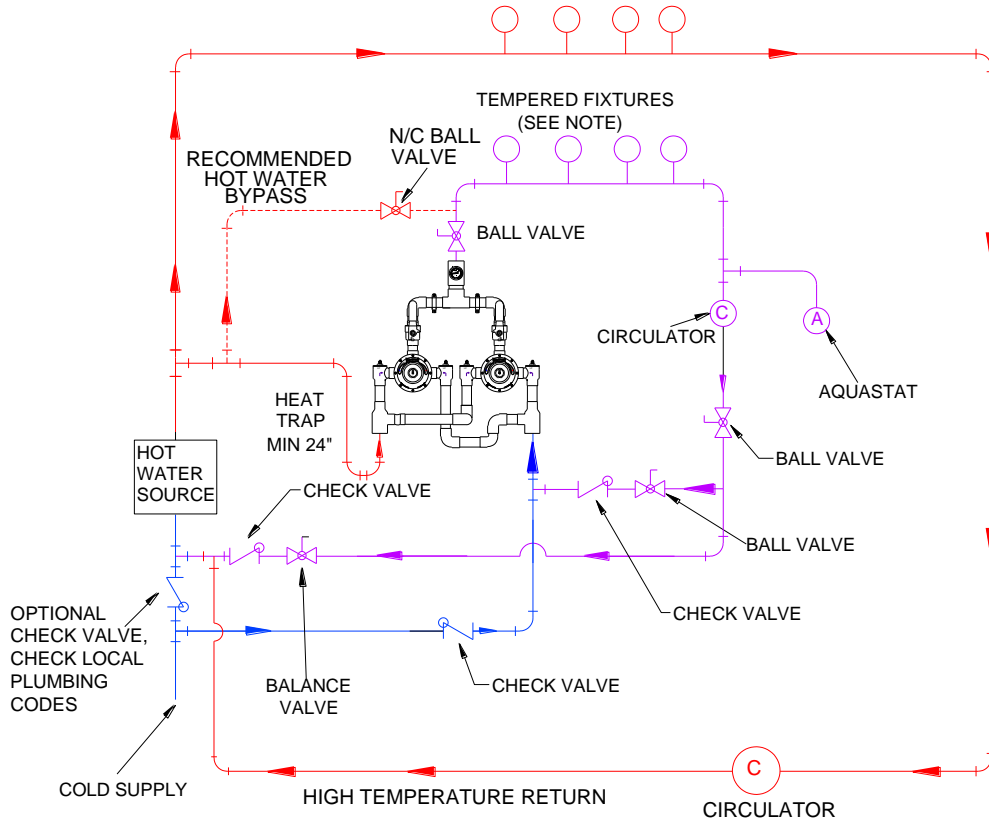

Note: The models shown represent Leonard Products which are believed to be equivalent in type and function to items specified. Leonard Valve Company is not responsible for errors or omissions due to differences in interpretations of information provided.

CAUTION! All thermostatic water mixing valves have limitations. They will NOT provide the desired accuracy outside of their flow capacity range. Consult the Flow Capacity Chart and DO NOT OVERSIZE. Minimum flow must be no less than as indicated.



1360 Elmwood Avenue, Cranston, RI 02910 USA

Phone: 401.461.1200 Fax: 401.941.5310

Email: info@leonardvalve.com

Web Site: <http://www.leonardvalve.com>