

EMERGENCY MIXING VALVES

ECO-MIX™

**Exposed Assembly for
Eye/Face Wash
2 - 9 GPM (7.6 - 34 l/min) flow rate
up to 45 PSI (3.1 bar) system pressure drop
TA-350-LF**

**DUAL MANIFOLD EMERGENCY
MIXING VALVE SYSTEM WITH
TEMPERATURE OVERRIDE
PROTECTION**

ASSE 1071 Certified

CSA Certified

TA-350-LF

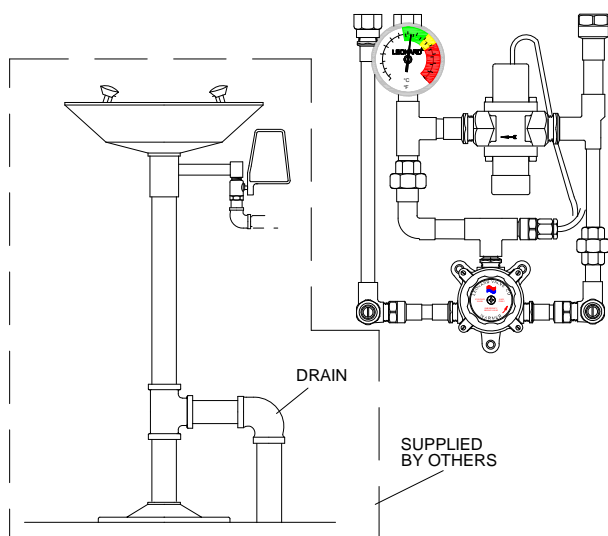

WARNING: This product can expose you to chemicals including lead, which is known to the State of California to cause cancer. For more information, go to www.P65Warnings.Ca.gov

This product is certified to meet Low Lead requirements of wetted surface area containing less than 0.25% lead by weight

Engineer's Approval	Job # _____
	Arch/Eng. _____
	Contractor _____

CAUTION! All thermostatic water mixing valves have limitations. They will NOT provide the desired accuracy outside of their flow capacity range. Consult the Flow Capacity Chart and DO NOT OVERSIZE. Minimum flow must be no less than as indicated.

***NOTE:** A limit stop, set for 90°F (32°C), is simply a mechanical setting to prevent excessive handle rotation. If incoming water is hotter than 135°F (57°C), the temperature of the factory test, the valve when turned to full HOT may deliver water in excess of 90°F and the limit stop MUST BE RESET BY THE INSTALLER

PRIMARY EMERGENCY WATER MIXING VALVE

- DURA-trol® solid bimetal thermostat directly linked to valve porting to control the intake of hot and cold water and compensate for supply temperature and pressure fluctuations. DURA-trol® is highly responsive and cannot be damaged by extremes in temperature
- Primary valve can be set to the correct temperature for the application.
- Locking type temperature regulator to prevent accidental movement set for 85°F (29°C)
- Primary mixing valve will close down on failure of cold water supply
- Primary Mixing Valve with special internal cold water bypass capable of 4 GPM (15 l/min) @ 30 PSI (2.1 Bar) upon failure of hot water supply
- Adjustable high temperature limit stop * set for 90°F (32°C)
- Full 3/4" top inlets and 3/4" top outlet
- Integral wall support
- Dial thermometer (range 0 to 140°F, -10 to 60°C)
- Rough bronze finish
- Straight checkstops on inlets
- Compliance.....ANSI Z358-1

REDUNDANT THERMOSTATIC CONTROL VALVE

- Stainless steel bellows thermostat is factory locked @ 90°F, 32°C (adjustable from (40°F to 100°F), (4°C to 32°C)) to allow cold water to enter the outlet side of the Primary mixing valve
- Remains fully closed until outlet temperature reaches 90°F (32°C)
- Will keep maximum temperature at or below 90°F should primary valve allow water in excess of 90°F (32°C)
- Maximum supply temperature 180°F (82°C)
- Maximum supply pressure 125 PSI (8.6 Bar)

OPTIONS:

___SUFFIX IT- Inlet thermometers



1360 Elmwood Avenue, Cranston, RI 02910 USA
Phone: 401.461.1200 Fax: 401.941.5310
Email: info@leonardvalve.com
Web Site: <http://www.leonardvalve.com>

EMERGENCY WATER MIXING VALVE FOR EYE/FACE WASH

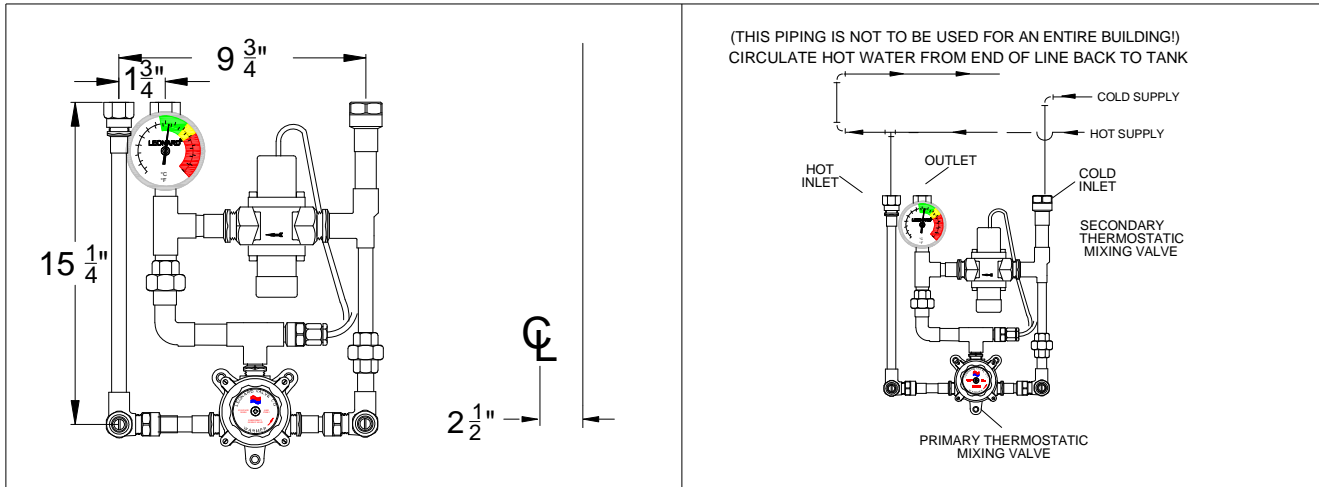

CAUTION! It may be necessary to recirculate the tempered water to the eye/face wash should the piping be exposed to excessive hot or cold conditions. Consult factory for proper piping.

FLOW CAPACITIES

MODEL	IN	OUT	MINIMUM FLOW (GPM) L/MIN	INTERNAL COLD WATER BY-PASS MINIMUM	PRESSURE DROP										PSI BAR
					5	10	15	20	25	30	35	40	45		
TA-350-LF	1/2"	1/2"	2.0	4	2.0	2.7	3.5	4.5	5.5	6.5	7.5	8.5	9.0	GPM	
			7.6	15	7.6	10	13	17	21	25	28	32	34	L/MIN	
MAXIMUM FLOW CAPACITY															

The Emergency eye/face wash Mixing Valve shall control and maintain the temperature of the water to the station. Unit shall be self contained and include a thermostatic water mixing valve, a dial thermometer on the outlet, angle checkstops, wall mounting bracket, piping and fittings factory assembled and tested, top or bottom inlets and top outlet, unit set for 85°F (29°C) and a maximum temperature of 90°F (32°C). The redundant valve remains fully closed until outlet temperature reaches 90°F (32°C), and will keep the maximum temperature at 90°F should the primary valve allow water in excess of this temperature. Unit must be able to be set to the correct temperature for the specific contaminant but must be locked in place to prevent changing of the temperature by accident. Unit must be checked weekly for performance in conjunction with the requirements of ANSI Z358.1. Unit shall be able to flow a minimum flow of 4 GPM (15 l/min) at 30 PSI (2.1 Bar).

WARNING! IT IS THE RESPONSIBILITY OF THE SPECIFIER TO DETERMINE THE DELIVERED WATER TEMPERATURE TO EACH SAFETY FIXTURE. A COMFORTABLE RANGE IS 60°F TO 90°F (15° TO 32°C). IN CIRCUMSTANCES WHERE A CHEMICAL REACTION IS ACCELERATED BY WATER TEMPERATURE, A MEDICAL ADVISOR SHOULD BE CONSULTED FOR THE OPTIMUM TEMPERATURE FOR EACH APPLICATION.

Specifications are subject to change without notice!

CAUTION! All thermostatic water mixing valves have limitations. They will NOT provide the desired accuracy outside of their flow capacity range. Consult the Flow Capacity Chart and DO NOT OVERSIZE. Minimum flow must be no less than indicated.



1360 Elmwood Avenue, Cranston, RI 02910 USA
 Phone: 401.461.1200 Fax: 401.941.5310
 Email: info@leonardvalve.com
 Web Site: <http://www.leonardvalve.com>